



SI5200/SI5400/SI5400e

Document Inserting System



Operator Guide Addendum
US English Version

Statement of FCC Compliance

This equipment has been tested and found to comply with the limits for a Class A digital device, pursuant to part 15 of the FCC rules. These limits are designed to provide reasonable protection against interference when the equipment is operated in a commercial environment. This equipment generates, uses, and can radiate radio frequency energy and, if not installed and used in accordance with the instruction manual, may cause interference to radio communications. Operation of this equipment in a residential area is likely to cause interference, in which case the user will be required to correct the interference at his own expense.

CAUTION: Changes or modifications to this equipment not expressly approved by the party responsible for compliance (SECAP) could void the user's authority to operate the equipment.

Canada

This class A digital apparatus complies with Canadian ICES-003.

Cet appareil numérique de la classe A est conforme à la norme NMB-003 du Canada.

SV62169 Rev. A 4/08 ©2008 SECAP

All rights reserved. This book may not be reproduced in whole or in part in any fashion or stored in a retrieval system of any type or transmitted by any means, electronically or mechanically, without the express, written permission of SECAP. We have made every reasonable effort to ensure the accuracy and usefulness of this manual; however, we cannot assume responsibility for errors or omissions or liability for the misuse or misapplication of our products.

Due to our continuing program of product improvement, equipment and material specifications as well as performance features are subject to change without notice. FastPac, SwiftStart, SureTrac, Optiflow, IntelliLink and E-Z Seal are trademarks or registered trademarks of Pitney Bowes.

Contents



Introduction.....	4
Meet the Inserting System.....	4
Fixed Function Keys	4
Basic Operation	7
Powering Up	7
Making Pre-Run Adjustments	8
Creating a Job	9
Creating a Job that Uses the Universal Feeder.....	11
Job Options	14
Selecting a Job	24
Troubleshooting.....	26
Reference	31
System Specifications	31
Universal Feeder	31
Feeder Tower Sheet Specifications	31
SI5200/SI5400 Input Transport.....	32
Add Ons and Options	33
Universal Feeder	33
High Capacity Loader (Optional)	34
SI5200/SI5400 Input Transport.....	35
Scanning.....	40
Scanning Features	40

SI5200/SI5400/SI5400e Operator Guide Addendum

Introduction

This document contains information about the new features and options available for the SI5200/SI5400 Inserting System. This document should be used in conjunction with the *SI5200/SI5400 Document Inserting System Operator Guide*.

NOTE: The availability of add-ons and options for your inserting system varies by region. Refer to your system supplier for availability details.

New Features

- The inserter can single fold up to 10 20 lb. sheets.
- The inserter supports multiple inserts into flat envelopes.
- The inserter supports mail pieces that include inflexible inserts in envelopes having a depth of 6 in. (152.4 mm) to 7 in. (177.8 mm).
- The inserter supports marking of every nth envelope if the Flats Sealer is present on the system.

Meet the Inserting System

The information in this section is intended for use as a replacement or supplement to information contained in “Chapter 2, Meet the Inserting System” in the *SI5200/SI5400 Document Inserting System Operator Guide*.

Fixed Function Keys

The Fixed Function Keys are the top row of keys under the screen. Each of these keys has an assigned function that is enabled or disabled based on the screen that displays. Use of each of these keys is explained next in more detail.

Fixed Function Keys (continued)

Reset Counters

The system has two counters:

- Piece Counter
- Batch Counter

NOTE: If the Flats Sealer is present on the system, the "Mark Piece Count" option will be available on this screen. When the "Mark Piece Count" option is available, the "Both" reset option changes to "All". Refer to Chapter 7 in the *SI5200/SI5400 Document Inserting System Operator Guide* for more information about the Flats Sealer.

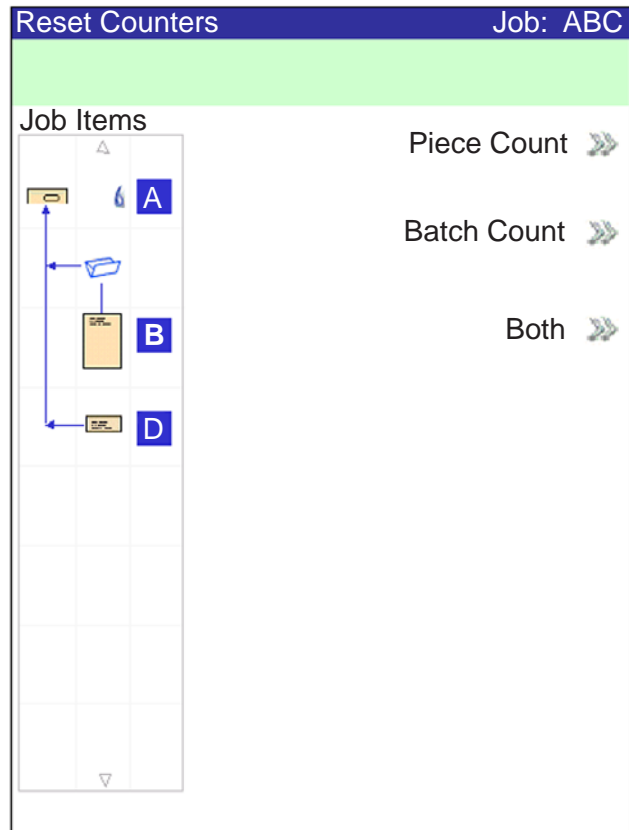

Reset Counters Screen

Resetting the Piece Counter

The Piece Counter appears in the bottom portion of the Display screen. It is a cumulative counter, i.e., it increments for each completed mail piece.

If you run the same job but for a different customer and/or use different materials, you'll need to zero the counter and ready it for counting the completed mail pieces in the new run.

To reset the Piece Counter:

1. Press RESET COUNTERS to display the Reset Counters screen.
2. Select "Piece Count".
3. You will be returned to the Home screen. The Piece Counter at the bottom of the screen will read "0".

Fixed Function Keys (continued)

Resetting the Batch Counter

The Batch Counter counts up to a set number. It increments one count for each completed mail piece that the system detects. The system stops when it reaches the batch count.

To reset the desired number for the job you are running:

1. Press RESET COUNTERS to display the Reset Counters screen.
2. Select "Batch Count".
3. You will be returned to the Home screen. The Batch Counter at the bottom of the screen will return to its original setting.

NOTE: The original setting for the Batch Counter cannot be less than "5" or greater than "9999".

Resetting the Mark Piece Count

The Mark Piece Count selection allows you to reset the counter for the envelope edge mark to zero.

1. Press RESET COUNTERS to display the Reset Counters screen.
2. Select "Mark Piece Count".
3. You will be returned to the Home screen. The counter will be reset to zero.

Resetting Both (or All) Counters

The Both selection allows you to reset both the Piece Counter *and* the Batch Counter to zero.

1. Press RESET COUNTERS to display the Reset Counters screen.
2. Select "Both".

NOTE: If the Mark Piece Count option is available, select "All." The counter for the envelope edge mark will be reset to zero as well.

3. You will be returned to the Home screen. The Piece Counter at the bottom of the screen will read "0" and the Batch Counter will return to its original setting.

Basic Operation The information in this section is intended for use as a replacement or supplement to information contained in “Chapter 3, Basic Operation” in the *SI5200/SI5400 Document Inserting System Operator Guide*. These instructions explain how to:

- properly power up the inserting system;
- create a job using the Universal Feeder on the SI5200/SI5400 Inserting System; and

NOTE: You should be thoroughly familiar with each component of the Universal Feeder and the optional High Capacity Loader before creating a job on the SI5200/SI5400 Inserting System (see the *Universal Feeder/High Capacity Loader Operator Guide* supplied with the system).

-
- select a job.

Powering Up

Press the ON/OFF switch (located below the Control Panel) to start the power up process.

IMPORTANT:

- If additional modules are present (e.g. High Capacity Sheet Feeder, Universal Feeder, SI5200/SI5400 Input Transport, Exit Transport), power on each module from left to right.
- When powering the system off and on, be sure to power off all modules, from left to right, then power them all back on from left to right.

The system will automatically conduct a number of checks to verify the operational integrity of the system. If any problems are detected, the system will display information directing you to a solution to the problem.

Making Pre-Run Adjustments

Adjusting the Manual Lever for Stiff Media Mode (SI5400e Only)

Mail pieces with stiff inserts leave the machine through the flats exit. The Stiff media feature requires manual lever (with sensor) to hold the flats gate open. This hardware is included with SI5400e inserters.

If the stiff media hardware is present, one or more of any insert type may be designated “stiff”.

- Most common case is a single stiff insert from the Input Transport.
- Also possible is a job with multiple inserts from the tower that, taken together, are stiff.

Once one or more inserts have been designated “stiff”, the job requires an envelope of length 6 in. (152.4 mm) to 7 in. (177.8 mm) and the manual lever placed in the flats position.

- Envelopes must be fed from the Feeder Tower; the HCEF cannot be used.
- Since mail piece components may be too short to leave the machine through the flats exit when they are not in an envelope, CLEAR DECK does not function in Stiff Media mode. Instead, you must clear the machine manually.

To adjust the manual lever for Stiff Media mode:

1. Open the Sealer cover.
2. Adjust the lever to the stiff media position.
3. Close the Sealer cover.

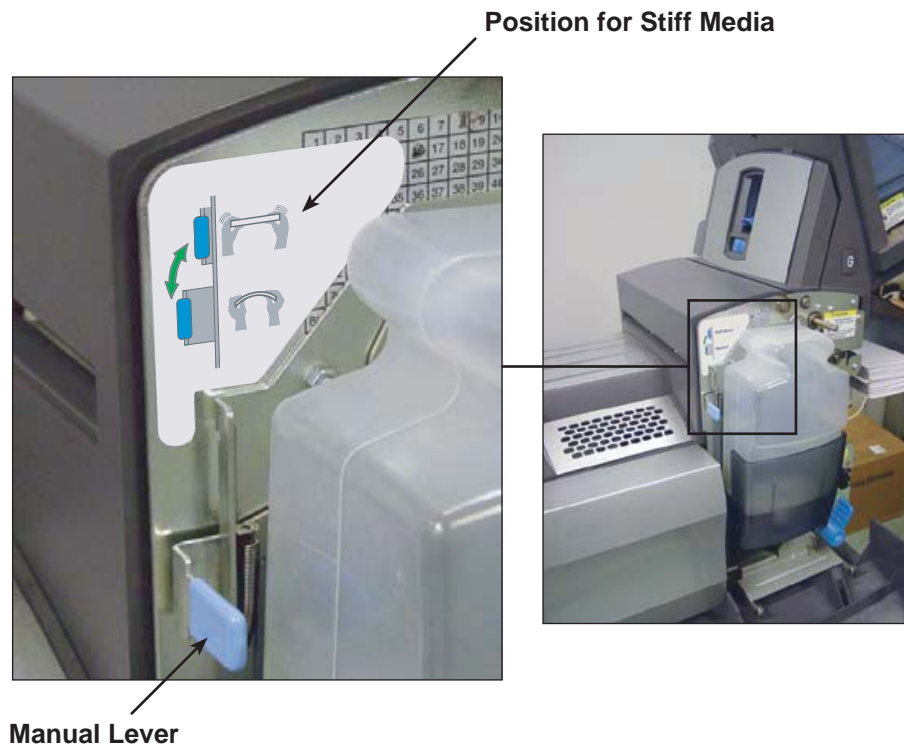

SI5200/SI5400/SI5400e Operator Guide Addendum

Creating a Job

The Stiff Media option is an addition to the “Menu Options” table on page 3-27 of the *SI5200/SI5400 Document Inserting System Operator Guide*:

Reply Card Reply Envelope Pre-Folded Insert Small Booklet Slip Generic Insert Large Booklet Stiff Media*	<p>a. If this is a scanning job, follow the steps below. Otherwise, go to step b.</p> <ul style="list-style-type: none"> • The Scan Type screen displays. Select the appropriate Scan Type (OMR, Code 3 of 9, or Interleaved 2 of 5.) • The Scan Configuration screen displays. Select the appropriate Scan Configuration. • The Content - In Line with Marks screen displays. <i>If there is content in line with the scan marks, select "Yes". If there is no content in line with the scan marks, select "No".</i> <p>b. Select the appropriate options for the insert. Press “Accept” when done.</p> <p>Refer to the “Insert Options” table in Chapter 3 of the <i>SI5200/SI5400 Document Inserting System Operator Guide</i> for specific information about each of the related menu options.</p>
---	---

*The SI5400e is required to feed this item.

The following definition is an addition to the “Menu Options” table on page 3-29 of the *SI5200/SI5400 Document Inserting System Operator Guide*:

Mark Piece Count	<p>Select this option if you have a Flats Sealer and want to use the envelope edge marker to mark every nth envelope. Use the numeric matrix to enter the appropriate value.</p> <p>NOTE: The Flats Sealer is a purchasable exit option. Only letter-sized envelopes can be marked using the envelope edge marker. Refer to Chapter 7 of the <i>SI5200/SI5400 Document Inserting System Operator Guide</i> for more information about the Flats Sealer.</p>
-------------------------	--

The following replaces the “Length of Clear Zone” definition on page 3-35 of the *SI5200/SI5400 Document Inserting System Operator Guide*:

Additional Settings (continued)	<p>- <i>Length of Clear Zone</i> is the total length of the scan marks plus the Clear Zones before and after the scan marks.</p>
--	--

SI5200/SI5400/SI5400e Operator Guide Addendum

Creating a Job (continued)

The following replaces the “Insert Type” definition on page 3-36 of the *SI5200/SI5400 Document Inserting System Operator Guide*:

<p>Insert Type includes all items that do not need folding or have been pre-folded.</p>	<ul style="list-style-type: none"> • <i>Reply Envelope</i> - is also called a Business Reply Envelope. • <i>Reply Card</i> - is a thick slip. • <i>Pre-folded Insert</i> - is a sheet or set of sheets already folded together. • <i>Small Booklet</i> - is a type of insert that typically has a bound or stapled edge. • <i>Slip</i> - is single thickness document that fits into the outer envelope without folding. • <i>Generic</i> - is an undeclared type of insert used by SwiftStart™ jobs. • <i>Large Booklet</i> - is a type of insert that typically has a bound or stapled edge. <p>NOTE: A Custom Feeder is required to feed this item.</p> <ul style="list-style-type: none"> • Stiff Media - is a type of insert that is inflexible. <p>NOTE: The SI5400e is required to feed this item. Once one (or more) Stiff Media insert has been selected, the job requires an outer envelope length of 6 in. (152.4 mm) to 7 in. (177.8 mm). In addition, the manual lever for Stiff Media must be placed in the flats position in order to run the job. Refer to <i>Making Pre-Run Adjustments</i> in this document for more information.</p>
--	---

The following replaces the “Quantity” definition on page 3-36 of the *SI5200/SI5400 Document Inserting System Operator Guide*:

<p>Quantity is the number of this particular insert to include in each mail piece.</p> <p>NOTE: This menu option is not available when “Large Booklet” is the selected insert.</p>	<ul style="list-style-type: none"> • 1, 2, 3, 4, 5, 6 • <i>Custom Quantity</i> <ul style="list-style-type: none"> - Use UP/DOWN arrow keys to select number. - Select "Accept" when done. • <i>Variable</i> - used with scanning-controlled jobs.
--	---

The following replaces the “Item Over Count Quantity” definition on page 3-38 of the *SI5200/SI5400 Document Inserting System Operator Guide*:

<p>Additional Settings (continued)</p>	<ul style="list-style-type: none"> • <i>Item Over Count Quantity</i> is the number of inserts that cannot be run normally.
---	---

The following replaces the “Batch Mode” definition on page 3-39 of the *SI5200/SI5400 Document Inserting System Operator Guide*:

<p>Batch Mode</p>	<p>Toggle:</p> <ul style="list-style-type: none"> • <i>Off</i> means this feature will not function for this job, or • <i>On</i> means this feature is active.
--------------------------	--

Creating a Job that Uses the Universal Feeder

Creating a new job involves defining the contents of a new mail piece, and optionally, saving the job for future use. This process consists of identifying each item in the mail piece and selecting settings for the job. A Mail Piece Icon Tree automatically builds on the screen as you add items.

To access the Create New Job screen:

1. From the Home screen, select “Menu”, then “Jobs”, and finally “Create New Job.” The Create Job screen displays.
2. Enter the Job Name using the alphanumeric matrix.
 - a. Use the UP/DOWN and LEFT/RIGHT arrow keys to select a letter.
 - b. Press OK to add the letter to the job name. Highlight the arrow character and press OK to move the cursor within the job name.
 - c. Select “Accept Name” when done.
3. If scanning is present on the system, the Create - Job Type screen displays.
 - If the new job does not require scanning, select "Normal Type" to continue.
 - If the new job requires scanning, select "Scanning Job".
4. The Create Outer Envelope screen displays.
 - If the job does not require an Outer Envelope, select "No".
 - If the job requires an Outer Envelope, select “Yes.”
 - Select the appropriate Outer Envelope options for the job. Refer to the *Envelope Options* table in this document for more information about each of the related menu options.
 - Press “Accept” when done.
 - If the job is a scanning job, the Create - Only One Envelope screen displays. If the job requires only one envelope, select "Yes" and proceed to step 5.
 - If the job requires an additional envelope, select "No, Two Outer Envelopes". Validate the available options, and press "Accept" when done.

NOTE: If this is a scanning job, and you will be using dynamic envelope selection, you must select “No, Two Outer Envelopes”.

SI5200/SI5400/SI5400e Operator Guide Addendum

Creating a Job that Uses the Universal Feeder (continued)

5. The Create - Select Next Item screen displays. Select the appropriate option.

NOTE: These instructions apply to items being fed by the Universal Feeder.

Menu Options	Associated Options/Actions
<p>Reply Card Reply Envelope Pre-Folded Insert Small Booklet Slip Generic Insert Large Booklet Stiff Media</p>	<p>a. If this is a scanning job, follow the steps in this section. Otherwise, go to step b. The Scan Type screen displays. Select "External Scan Definition". NOTE: The External Scan Definition option is only available if the Universal Feeder is present on the system. If the job requires a Universal Feeder, <i>External Scan Definition is the only available option.</i></p> <p>b. Select the appropriate options for the insert. Press "Accept" when done. Refer to the <i>Insert Options</i> section in this document for specific information about each of the related menu options.</p>
<p>Sheet</p>	<p>a. Select the "Custom Feeder" option. The Sheet - Personalized Create screen appears. Select the appropriate personalization option. The Create - Verify Sheet screen appears.</p> <p>b. If this is a scanning job, follow the steps below. Otherwise, go to step c.</p> <ul style="list-style-type: none"> • The Scan Type screen displays. Select "External Scan Definition". NOTE: The External Scan Definition option is only available if the Custom Feeder is present on the system. If the job requires a Custom Feeder, External Scan Definition is the only available option. • The Scan Configuration screen displays. Select the appropriate Scan Configuration. • The Content in Line with Marks screen displays. <i>If there is content in line with the scan marks, select "Yes". If there is no content in line with the scan marks, select "No".</i> • If you selected "Yes", the Mark Locations Settings screen appears. Follow the steps below to enter the various mark-related measurements: <ul style="list-style-type: none"> - Select an option, then use the UP/DOWN arrow keys to enter the appropriate measurement (in millimeters). - Press "Accept" when done entering the measurement. - Once <i>all</i> measurements have been entered, select "Accept". <p>c. Select the appropriate Sheet options for the job. Press "Accept" when done. NOTE: If this is a scan job, set the Select Feed setting. Refer to the <i>Sheet Options</i> table in this document for more information about each of the related menu options.</p> <p>d. Select the appropriate Fold options for the sheet. Press "Accept" when done. Refer to the <i>Fold Options</i> table in this document for specific information about each of the related menu items.</p>

SI5200/SI5400/SI5400e Operator Guide Addendum

Creating a Job that Uses the Universal Feeder (continued)

6. Once you have finished adding a Sheet or Insert, the Add New Item screen appears.
 - Select "Yes" to add additional items to the job. Repeat step 4 as necessary.
 - Select "No" if you have finished adding items to the job.
7. The Create - Edit Job Settings screen displays. Select the appropriate options.

Menu Options	Associated Options/Actions
Job Comments	Use the alphanumeric matrix to enter any additional information related to the job. If the job will be saved by a supervisor or manager, you can make it easy for operators to identify/select the correct job in the future by entering a job description in the job comments area. NOTE: Job comments can contain up to 120 characters.
Batch Mode	Toggle: <ul style="list-style-type: none"> • <i>Off</i> means this feature will not function for this job, or • <i>On</i> means this feature is active.
Batch Count	Use the numeric matrix to enter the batch count value. NOTE: The batch count can contain up to four digits. The minimum is "5" and the maximum is "9999".
Set Over Max Count	Indicates what will happen to sets that exceed the set over count quantity. Choices include <i>Divert</i> and <i>Stop</i> .
Use Postage Meter	Select this option if you will be using the Mail Machine Interface (MMI). This interface enables communication between the Inserting System and either a DP Series DP800i or DP1000 mailing system via a USB connection. The system sends start and stop signals to the mailing system, and the mailing system can send error messages back to the inserter to stop feeding. Toggle: <ul style="list-style-type: none"> • <i>Off</i> means this feature will not function for this job, or • <i>On</i> means this feature is active. NOTE: The MMI is a purchasable exit option. Only letter-sized envelopes can be used with this interface. Refer to Chapter 7 of the <i>SI5200/SI5400 Document Inserting System Operator Guide</i> for more information about the MMI.
Mark Piece Count	Select this option if you have a Flats Sealer and want to use the envelope edge marker to mark every nth envelope. Use the numeric matrix to enter the appropriate value. NOTE: The Flats Sealer is a purchasable exit option. Only letter-sized envelopes can be marked using the envelope edge marker. Refer to Chapter 7 of the <i>SI5200/SI5400 Document Inserting System Operator Guide</i> for more information about the Flats Sealer.
Advanced	Allows access to advanced job settings. IMPORTANT: Do not change the advanced job settings unless instructed to do so. Changing settings may affect machine performance.

SI5200/SI5400/SI5400e Operator Guide Addendum

Creating a Job that Uses the Universal Feeder (continued)

8. Select "Accept" when done.
9. The Create - Saved Created Job screen displays.
 - Select "Yes, Save" to save the job (optional). You must have supervisor or manager access rights to save jobs.
 - Select "No, Save Later" if you do not have supervisor or manager access rights.

Job Options

This section contains descriptions of the various options you can add or modify when creating or editing a job.

Envelope Options

Menu Item	Associated Options and Actions
Name	Use the alphanumeric matrix to enter the envelope name.
Size refers specifically to the outer envelope that contains the final mail piece.	Toggle: <ul style="list-style-type: none"> • <i>Letter</i> generally has smaller depth and contains folded sheets, or • <i>Flat</i> generally is larger than Letter size and typically contains unfolded sheets. If the job will contain a Large Booklet, you must select this envelope size. Refer to <i>Envelopes</i> in Chapter 6 of the <i>SI5200/SI5400 Document Inserting System Operator Guide</i> for specification information.
Window allows use of windowed or non-windowed envelope.	Toggle: <ul style="list-style-type: none"> • <i>Yes</i> means you are using a windowed envelope, or • <i>No</i> means you are using a non-windowed envelope.
Type allows choice of windowed envelope.	<ul style="list-style-type: none"> • <i>Standard Flap</i> is a regular envelope. • <i>Forward Flap</i> means the window and flap are on the same side of the envelope. • <i>Bottom Flap</i> means the flap is at the bottom (instead of the top) of the envelope.
Seal refers to using the Moistener unit to close the envelope.	<ul style="list-style-type: none"> • <i>Off</i> means the envelope will not be sealed closed, or • <i>On</i> means the envelope will be sealed closed. • <i>Safe Seal</i> means the envelope will be sealed closed. However, the envelope moves through the system at a slower rate to provide more time for better sealing. This option is available only for flat envelopes, when the Flats Sealer is present on the system. <p>NOTE: If you are using a mailing machine in-line with the inserting system, you <i>must</i> instruct the system to seal the envelope.</p>
Depth is the dimension of an envelope from its flap fold to its opposite edge.	<ul style="list-style-type: none"> • <i>Auto Measure</i> - system measures depth when envelope is fed. • <i>Custom Depth</i> - allows you to enter the depth of the envelope. • Letter Options: #10 - 105 mm, #6 ¾ - 165 mm, C5 - 162 mm, C6 - 114 mm. Flat Options: #12 ½ - 317 mm, C4 - 229 mm.

Job Options (continued)

Envelope Options (continued)

Menu Item	Associated Options and Actions
Additional Settings	<p>Double Detect allows the system sense when multiple envelopes are fed unintentionally.</p> <ul style="list-style-type: none"> • <i>Double Detect Feature</i> allows you to toggle: <ul style="list-style-type: none"> - <i>Off</i> means this feature will not function for this item, or - <i>On</i> means this feature is active. • <i>Location</i> allows you to toggle: <ul style="list-style-type: none"> - <i>Default</i>, or - <i>Custom</i>. • <i>Custom Location for Top Edge</i> allows you to enter a specific measurement (distance from the edge feeding first into the feeder) where the system should attempt to detect a double. Set this option when Location is set to "Custom". <ul style="list-style-type: none"> - Use the UP/DOWN arrow keys to adjust the measurement (in millimeters). - Select "Accept" when you are done. <p>NOTE: The double detect region cannot be within 25 mm of the lead or trail edges of the envelope.</p> <p><i>If the envelope is feeding from the HCEF, measure from the bottom of the envelope.</i></p> <p><i>If the envelope is feeding from the Feeder Tower, measure from the top of the envelope. The custom location must be at least 5 mm away from the edge of the window (if present), at least 5 mm away from the edge of flap, and cannot lie on top of a seam.</i></p> <p><i>For best results, be sure to avoid areas that overlap with the window, flap, or seams.</i></p> <ul style="list-style-type: none"> • <i>Action On Double</i> allows you to select where the items should be fed to if a double is detected.
	<p>Feeder Type allows you to change the Feeder setting when material is problematic.</p> <ul style="list-style-type: none"> • <i>Normal</i> is used for most items. • <i>Special Feeder</i> helps problematic material run better. <p>NOTE: The Special Feeder is a purchasable option. If available, it will be located at the top left or right of the Feeder Tower. It is an option for one or more tower feeders to improve feeding of thin prefolded items or booklets with thin covers. It reduces the tendency of these items to separate while they are being fed. You must push the "Special Feeder" lever up to run a job when the Feeder Type is set to Special Feeder.</p>
	<p>Feeder Linking allows multiple Feeders to feed the same envelope.</p> <ul style="list-style-type: none"> • <i>None</i> means there is no linking of Feeder Trays. • <i>Two Feeders</i> indicates that two Feeder Trays are linked and feeding the same material. <p>NOTE: Feeders must be on the same module and on the same side of the tower to be linked. For scanned items, always load linked feeders at a collation break.</p>





SI5200/SI5400/SI5400e Operator Guide Addendum

Job Options (continued)

Envelope Options (continued)

Menu Item	Associated Options and Actions
Additional Settings (continued)	<p>Envelope Select Feed allows you to indicate when the envelope should be used.</p> <p>Toggle:</p> <ul style="list-style-type: none"> • <i>Main</i> • <i>Alternate</i> <p>NOTE: This option is enabled only when the Scan feature is activated, two Outer Envelopes have been defined in a job <i>and</i> either one of the following:</p> <ul style="list-style-type: none"> • The Item Over Count Action is set to "Use Alternate Envelope" on the control document in the job, OR • An Envelope Select mark is contained in the scan configuration file associated with the control document in the job.

Fold Options

Menu Item	Associated Options and Actions
<p>Fold Type refers to the way sheets are folded to be able to show certain portions through a window, and/or when a sheet is opened.</p>	<ul style="list-style-type: none"> • <i>C Fold</i>  • <i>Z Fold</i>  • <i>Single Fold</i>  • <i>Double Fold</i>  • <i>No Fold</i> 
<p>Auto Fold Lengths lets the system choose the type of fold.</p>	<p>Toggle:</p> <ul style="list-style-type: none"> • <i>Yes</i> means the system calculates the fold length, or • <i>No</i> means you will enter the fold lengths you want.
<p>Fold 1 Length Fold 2 Length</p>	<p>Fold Length is shown on the display screen for each fold type/address combination.</p> <ul style="list-style-type: none"> • Use the UP/DOWN Arrow Keys to select desired length. • Press "Accept" when done.

SI5200/SI5400/SI5400e Operator Guide Addendum

Job Options (continued)

Sheet Options

Menu Item	Associated Options and Actions
Name	Use the alphanumeric matrix to enter the job name.
Control Document is the top sheet in the Mail Piece Icon Tree. This field is read-only.	Read-Only field <ul style="list-style-type: none"> • Yes, or • No
Type identifies the printing source of the job.	<ul style="list-style-type: none"> • <i>Printed Separately</i> - indicates the sheet is not printed by the Attached Printer. • <i>Printed by Attached Printer</i> - indicates the sheet is printed by the Attached Printer. <p>NOTE: This menu option is available only with configurations that contain an Attached Printer. If an Attached Printer is not present, this option appears as a read-only field with "Printed Separately" as the default setting.</p>
Personalized refers to the top sheet that contains the address that will show in the windowed envelope and/or a sheet that contains information customized to a specific recipient.	<ul style="list-style-type: none"> • <i>Top Address</i> • <i>Middle Address</i> • <i>Bottom Address</i> • <i>Not Personalized</i> • <i>Personalized - No Address</i>
Quantity is the number of this type of sheet to include in each mail piece.	<ul style="list-style-type: none"> • 1, 2, 3, 4, 5, 6 • <i>Custom Quantity</i> <ul style="list-style-type: none"> - Use UP/DOWN arrows to select number. - Select "Accept" when done. <p>NOTE: Quantity is always set to Variable (n) for scanning jobs.</p>
Page Order identifies the feeding pattern of multiple sheets that are not identical.	<p><i>Forward</i> - indicates page 1 is on top and pages 2, 3, 4, etc. follow in that order.</p> <p><i>Reverse</i> - indicates that the last page, for example, page 4, is first followed by pages 3, then 2, then 1.</p> <p>NOTE: This menu option appears as a read-only field when the job requires a Custom Feeder. The feeding pattern is set by the Custom Feeder.</p>

SI5200/SI5400/SI5400e Operator Guide Addendum

Job Options (continued)

Sheet Options (continued)

Menu Item	Associated Options and Actions
<p>Length is the dimension of the sheet in the direction of the feed.</p>	<ul style="list-style-type: none"> • <i>Auto measure</i> - measures the recommended length automatically. <p>NOTE: This menu option appears as a read-only field when the job requires a Custom Feeder.</p> <ul style="list-style-type: none"> • <i>Custom Length</i> - allows increase or decrease of sheet length. <ul style="list-style-type: none"> - Use UP/DOWN arrows to select number. - Select "Accept" when done. <p>NOTE: If the job requires a Custom Feeder, you <u>must</u> enter the sheet length using the Custom Length option. The job will not be valid if the sheet length is not entered.</p> <ul style="list-style-type: none"> • <i>Letter - 279 mm, Legal - 356 mm, and A4 - 279 mm</i> are additional options. <p>NOTE: The "Legal" option is not available when the sheet is printed by the Attached Printer. Additionally, legal-sized documents cannot be fed from the High Capacity Sheet Feeder. The system will assign these documents to a Tower Feeder, even when the High Capacity Sheet Feeder is available.</p>
<p>Additional Settings.</p>	<p>Double Detect allows the system to sense when multiple sheets are fed unintentionally.</p> <p>NOTE: This menu option is not available when the job requires a Custom Feeder.</p> <ul style="list-style-type: none"> • <i>Double Detect Feature</i> allows you to toggle: <ul style="list-style-type: none"> - <i>Off</i> means this feature will not function for this item, or - <i>On</i> means this feature is active. • <i>Location</i> allows you to toggle: <ul style="list-style-type: none"> - <i>Default</i>, or - <i>Custom</i>. • <i>Custom Location for Top Edge</i> allows you to enter a specific measurement (the distance from the edge feeding first into the feeder) where the system should attempt to detect a double. <p>NOTE: Set this option when Location is set to "Custom". The double detect region cannot be within 25 mm of the lead or trail edges of the sheet.</p> <ul style="list-style-type: none"> - Use the UP/DOWN arrow keys to adjust the measurement (in millimeters). - Select "Accept" when you are done. <ul style="list-style-type: none"> • <i>Action On Double</i> allows you to select where the items should be fed to if a double is detected.

Job Options (continued)

Sheet Options (continued)

Menu Item	Associated Options and Actions
Additional Settings. (continued)	<p>Feeder Type allows you to change the Feeder setting when material is problematic, or to indicate that the job requires a Custom Feeder.</p> <p>NOTE: This menu option is not available when the job requires an Attached Printer.</p> <ul style="list-style-type: none"> • <i>Normal</i> is used for most items. • <i>Manual Feed</i> is used when items will be fed into the system by hand. Refer to “Manual Feeder” in Chapter 2 for more information. • <i>Custom Feeder</i> is used when items will be fed into the system by the Custom Feeder. <p>Feeder Linking allows multiple Feeders to feed the same material.</p> <p>NOTE: This menu option is not available when the job requires a Custom Feeder <i>or</i> an Attached Printer.</p> <ul style="list-style-type: none"> • <i>None</i> means there is no linking of Feeder Trays. • <i>Two Feeders</i> indicates that two Feeder Trays are linked and feeding the same material. <p>NOTE: Scanned sheets can be linked vertically in both the High Capacity Sheet Feeder and the Feeder Tower.</p> <p>Scan Items allows you to indicate whether or not an item should be scanned.</p> <p>Toggle:</p> <ul style="list-style-type: none"> • Yes means this feature is active, or • No means this feature will not function for the item.

SI5200/SI5400/SI5400e Operator Guide Addendum

Job Options (continued)

Insert Options

Menu Item	Associated Options and Actions
Name	Use the alphanumeric matrix to enter the job name.
Insert Type includes all items that do not need folding or have been pre-folded.	<ul style="list-style-type: none"> • <i>Reply Envelope</i> - is also called a Business Reply Envelope. • <i>Reply Card</i> - is a thick slip. • <i>Pre-folded Insert</i> - is a sheet or set of sheets already folded together. • <i>Small Booklet</i> - is a type of insert that typically has a bound or stapled edge. • <i>Slip</i> - is single thickness document that fits into the outer envelope without folding. • <i>Generic</i> - is an undeclared type of insert used by SwiftStart™ jobs. • <i>Large Booklet</i> - is a type of insert that typically has a bound or stapled edge. <p>NOTE: A Custom Feeder is required to feed this item.</p> <ul style="list-style-type: none"> • <i>Stiff Media</i> - is a type of insert that is inflexible. <p>NOTE: Once one or more “Stiff Media” insert has been selected, the job requires an outer envelope length 6 in. (152.4 mm) to 7 in. (177.8 mm). In addition, the Stiff Media lever must be placed in the flats position in order to run the job. Refer to <i>Making Pre-Run Adjustments</i> in this document for more information.</p>
Personalized means the insert contains information customized to a specific recipient. NOTE: This menu option is not available when “Large Booklet” is the selected insert.	Yes means there <u>is</u> unique information on this insert, or No means the insert does <u>not</u> contain unique information.
Quantity is the number of this particular insert to include in each mail piece. NOTE: This menu option is not available when “Large Booklet” is the selected insert.	<ul style="list-style-type: none"> • 1, 2, 3, 4, 5, 6 • <i>Custom Quantity</i> <ul style="list-style-type: none"> - Use UP/DOWN arrow keys to select number. - Select "Accept" when done. • <i>Variable</i> - used with scanning-controlled jobs.
Page Order identifies the feeding pattern of multiple inserts that are not identical. NOTE: This menu option is not available when “Large Booklet” is the selected insert.	<p><i>Forward</i> - indicates page 1 is on top and pages 2, 3, 4, etc. follow in that order.</p> <p><i>Reverse</i> - indicates that the last page, for example, page 4, is first followed by pages 3, then 2, then 1.</p>

Job Options (continued)

Insert Options (continued)

Menu Item	Associated Options and Actions
<p>Length is the dimension of the insert in the direction of the feed.</p>	<ul style="list-style-type: none"> • <i>Auto measure</i> - measures the recommended length automatically. NOTE: Auto measure is not available when "Large Booklet" is the selected insert or when the job requires a Custom Feeder. • <i>Custom Length</i> - allows increase or decrease of insert length. <ul style="list-style-type: none"> - Use the UP/DOWN Arrow Keys to select number. - Select "Accept" when done. NOTE: If the job requires a Large Booklet, you <u>must</u> enter the sheet length using this Custom Length option. The job will not be valid if the booklet length is not entered. • <i>Custom Length (Large Booklet Only)</i> - allows selection of large booklet size: 8.5" x 11" (215.9 mm x 279.4 mm) or 5.5" x 8.5" (139.7 mm x 215.9 mm). NOTE: If the job requires a Large Booklet, you <u>must</u> enter the sheet length using this Custom Length option. The job will not be valid if the booklet length is not entered.
<p>Additional Settings</p>	<p>Double Detect allows the system sense when multiple inserts are fed unintentionally. NOTE: This menu option is not available when the job requires a Custom Feeder.</p> <ul style="list-style-type: none"> • <i>Double Detect Feature</i> allows you to toggle: <ul style="list-style-type: none"> - <i>Off</i> means this feature will not function for this item, or - <i>On</i> means this feature is active. • <i>Location</i> allows you to toggle: <ul style="list-style-type: none"> - <i>Default</i>, or - <i>Custom</i>. • <i>Custom Location for Top Edge</i> allows you to enter a specific measurement (the distance from the edge feeding first into the feeder) where the system should attempt to detect a double. NOTE: Set this option when Location is set to "Custom". The double detect region cannot be within 25 mm of the lead or trail edges of the insert. <ul style="list-style-type: none"> - Use the UP/DOWN arrow keys to adjust the measurement (in millimeters). - Select "Accept" when you are done. • <i>Action On Double</i> allows you to select where the items should be fed to if a double is detected.

Job Options (continued)

Insert Options (continued)

Menu Item	Associated Options and Actions
Additional Settings (continued)	<p>Feeder Type allows you to change the Feeder setting when material is problematic, or to indicate that the job requires a Custom Feeder.</p> <p>NOTE: This menu option is not available when the job requires an Attached Printer. The Custom Feeder is selected automatically when "Large Booklet" is the selected insert.</p> <ul style="list-style-type: none"> • <i>Normal</i> is used for most items. • <i>Manual Feed</i> is used when items will be fed into the system by hand. Refer to "Manual Feeder" in Chapter 2 for more information. • <i>Custom Feeder</i> is used when items will be fed into the system by the Custom Feeder.
	<p>Feeder Linking allows multiple Feeders to feed the same material.</p> <p>NOTE: This menu option is not available when the job requires a Custom Feeder.</p> <ul style="list-style-type: none"> • <i>None</i> means there is no linking of Feeder Trays. • <i>Two Feeders</i> indicates that two Feeder Trays are linked and feeding the same material.
	<p>Scan Items allows you to indicate whether or not an item should be scanned.</p> <p>Toggle:</p> <ul style="list-style-type: none"> • Yes means this feature is active, or • No means this feature will not function for the item.

Job Options (continued)

Insert Options (continued)

Menu Item	Associated Options and Actions
Additional Settings (continued)	<p>Scan Settings</p> <p>NOTE: The “Content in Line with Marks”, “Marks On”, “Marks on First Page Only”, and “Mark Location Settings” options are not available when the job requires a Custom Feeder.</p> <ul style="list-style-type: none"> • <i>Scan Configuration</i> allows choice of saved scan configurations to interpret scan marks. • <i>Content in Line with Marks</i> indicates that content is in line with the scan marks in the feed direction. • <i>Marks On</i> indicates if marks are on the front or back of the page. • <i>Marks on First Page Only</i> indicates marks are on only the first of multiple inserts. • <i>Mark Location Settings</i> allows setup of various mark-related measurements. <ul style="list-style-type: none"> - <i>Top of Page to First Mark</i> is the distance from the top of the page to the first mark. - <i>Total Length of Marks</i> is the length from the top of the first possible mark to the bottom of the last mark. - <i>Top of Page to Clear Zone</i> is distance from the top of the page to the beginning of the Clear Zone. - <i>Length of Clear Zone</i> is the total length of the scan marks plus the Clear Zones before and after the scan marks. <p>Refer to “OMR Specifications” in Chapter 8 for more information on the Clear Zone and mark location settings.</p> • <i>Item Over Count Quantity</i> is the number of inserts that cannot be run normally. <p>NOTE: At this time, only a single insert can be added to each mail piece. When using a flat envelope, the insert must be a Reply Envelope (BRE).</p> • <i>Item Over Count Action</i> indicates what will happen to items that exceed the item over count quantity. Choices include: <ul style="list-style-type: none"> - <i>Divert</i> - Select this option if the Scan Configuration does not have the Divert Sheet (DVS) scan mark, and you want the system to divert items once the item over count quantity has been exceeded. - <i>Stop</i> - Select this option if you want the system to stop processing items once the item over count quantity has been exceeded. <p>Refer to <i>Scanning Features</i> in Chapter 8 for more information on divert sheet functionality.</p> <p>Select Feed (SF) Settings allows assignment of a Feeder to one of the 9 Select Feed scan marks.</p> <p>NOTE: This option is not available if the item requires a Custom Feeder and a High Capacity Sheet Feeder is part of the configuration.</p>

Selecting a Job

If the job that you want to run is the one that currently displays in the Home screen, proceed to the *Running a Trial Piece* section of this chapter.

IMPORTANT: If the job requires the Universal Feeder, you must select the job on the Universal Feeder *and* on the inserter before running a Trial Piece.

- Select the job on the inserter *first* to avoid job validation errors on the Universal Feeder.
- The “Custom Feeder not Ready” message will appear on the display screen if the selected job requires the Universal Feeder and the job is not selected on the Universal Feeder.

Refer to “Chapter 2, Operation, Select the Program” in the *Universal Feeder/High Capacity Loader Operator Guide* for information about selecting the job at the Universal Feeder.

If the job that you want to run is not displayed on the Home screen, follow the steps below to select the job.

1. From the Home screen:

- Select "Select Another Job" to view a list of saved jobs. Skip to step 3, below.

OR

- Select "Menu", then "Jobs", and finally "Select Job". The Select Job Type screen displays.



Select Job Type Screen

Selecting a Job (continued)

2. The Job Type screen provides access to all the jobs that are in your system. This screen displays three categories to search for the job that you want to run:
 - "Saved Jobs" displays the list of jobs that you created and saved.
 - "Recently Run Jobs" displays a list of the last 8 jobs that your system ran. This list shows each job's name and the date/time that the job ran.
 - "Library Jobs" displays the names of the pre-defined jobs that came loaded on your system.

Select the desired category to display the list of jobs that are available in that category.

3. Select the desired job from the list.
 - If the job does not appear on the first page, use the UP/DOWN arrow keys to scroll through the list.
 - As any job is highlighted in the list, the Mail Piece Icon Tree for the job appears on the display so that it can be identified
4. If you are using a Universal Feeder for this job, you must select the appropriate job on the Universal Feeder. Refer to "Chapter 2, Operation, Select the Program" in the *Universal Feeder/High Capacity Loader Operator Guide*.

SI5200/SI5400/SI5400e Operator Guide Addendum

Troubleshooting The information in this section is intended for use as a replacement or supplement to information contained in “Chapter 5, Troubleshooting” in the *SI5200/SI5400 Document Inserting System Operator Guide*.

Table 5-6 Insertion Area/Envelope Flapper Area Problems

Problem	Cause	Action
Stoppage in insertion area or flapper area; failure to insert.	Outer envelope is skewed.	Check Side Guides; incorrect adjustment can cause skewing. Refer to “Adjusting Tray Side Guides” in Chapter 3 of this guide for instructions.
	Envelope openers improperly adjusted.	The standard insertion finger configuration is five fingers (three inner envelope openers and two outer envelope openers). The alternative configuration is three fingers (three inner envelope openers). To obtain the alternative configuration, slide the fingers outside of the envelope. If the envelope is too wide to have the fingers completely out of the envelope, take the lower part of the outside fingers off.

Envelope Size	Fulls Size Booklet	Sheets	Insert/Small Booklet	Recommended Finger Setting
Flat	No	Yes	Yes	3
	Yes	Yes	No	3
	Yes	Yes	Yes	3
	Yes	No	No	3
	Yes	No	Yes	3
	No	Yes	No	5
Letter, DL, 6x9 and C5	n/a	Yes	No	5
	n/a	Yes	Yes	5*

*3 fingers if collation is thicker than 4 mm.

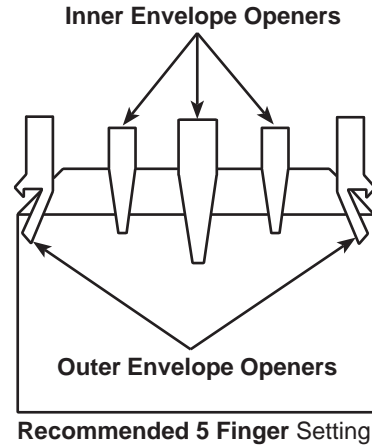
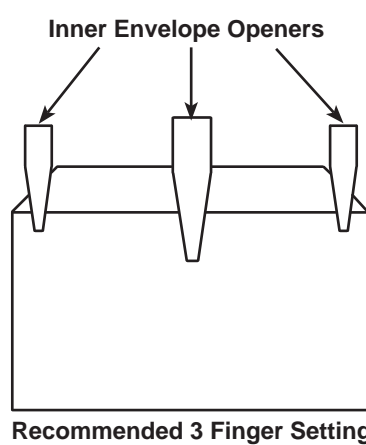

Troubleshooting (continued)

Table 5-6 Insertion Area/Envelope Flapper Area Problems

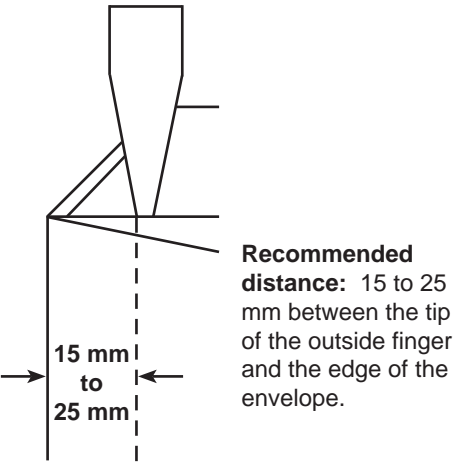
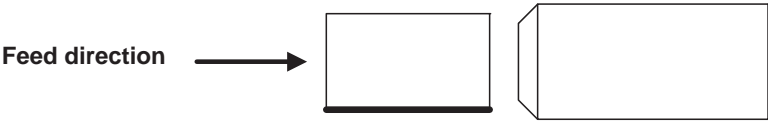
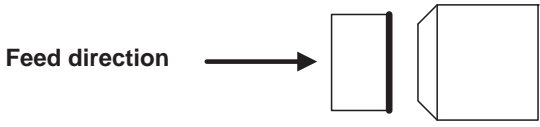
Problem	Cause	Action
<p>Stoppage in insertion area or flapper area; failure to insert. (continued)</p>	<p>Envelope opens improperly adjusted. (continued)</p>	 <p>Recommended distance: 15 to 25 mm between the tip of the outside finger and the edge of the envelope.</p>
<p>Large booklet: Binding must be parallel to the feed direction; most likely booklets that are inserted in flat envelopes that are close to the size of a full sheet.</p>  <p>Binding parallel to feed direction</p> <p>Small booklet: Binding must be perpendicular to the feed direction; most likely booklets that are inserted in C5 or 6x9 envelopes.</p>  <p>Binding perpendicular to feed direction</p> <p>Refer to "Adjusting the Envelope Openers" in Chapter 3 of this guide for instructions to perform the setup adjustment.</p>		
<p>Insufficient edge clearance.</p>		<p>Check clearance: envelope width must be <i>at least</i> 13 mm greater than the sum of the width of the widest insert <i>plus</i> the insert pack thickness.</p>
<p>Insertion pack or envelopes not centered.</p>		<p>Ensure that Side Guides are set correctly. Too much clearance between Side Guides and material can cause material to become skewed in machine.</p> <p>Refer to "Adjusting Tray Side Guides" in Chapter 3 of this guide for instructions.</p>

Troubleshooting (continued)

Table 5-6 Insertion Area/Envelope Flapper Area Problems		
Problem	Cause	Action
Stoppage in insertion area or flapper area; failure to insert. (continued)	<ul style="list-style-type: none"> Contents of insertion pack are catching on side seam inside of envelope. Contents of insertion pack are thick and difficult to insert into smaller envelopes. 	<p>Adjust the Aligner custom settings:</p> <p>NOTE: If the contents of the insertion pack are thick, and you are having trouble inserting the pack into a small envelope, be sure to set the "Envelope Width" and "Widest Enclosure Width" to the exact dimensions of the insertion pack.</p> <ol style="list-style-type: none"> From the Home screen, select "Menu", then "Jobs". Select "Edit Current Job", "Edit Job Settings", then "Advanced". Select "Aligner", then "On with Custom Settings". The Customer Aligner Settings screen displays. Select "Envelope Width". Use the UP/DOWN arrow keys to increase or decrease the measurement, as necessary. Select "Accept" when done. Select "Widest Enclosure Width". Use the UP/DOWN arrow keys to increase or decrease the measurement, as necessary. Select "Accept" when done. Select "Accept" on the Custom Aligner Settings screen once the necessary adjustments have been made.

Troubleshooting (continued)

Table 5-7 Moistener/Mail Piece Exit Problems		
Problem	Cause	Action
No seal, failure to seal, incomplete seals.	Sealing is off in job set up.	<ul style="list-style-type: none"> • Check job definition. • Make sure sealer is ON.
	Low sealant level.	Add water or sealing solution.
	Poor quality envelopes.	Inspect envelopes. Examine glue lines.
	Worn moistener brushes.	Inspect. Replace if necessary. Refer to <i>Replacing the Moistener Brushes</i> for instructions.
	Worn moistener wick.	Inspect. Replace if necessary. Refer to <i>Replacing the Moistener Wick</i> for instructions.
High seal: flap is folded and sealed above crease line.	Outer envelope or content skew.	<ul style="list-style-type: none"> • Check Side Guide adjustment. • Check for proper loading of material in Trays.
	<ul style="list-style-type: none"> • Contents of insertion pack are catching on side seam inside of envelope. • Contents of insertion pack are thick and difficult to insert into smaller envelopes. 	Adjust the Aligner custom settings: NOTE: If the contents of the insertion pack are thick, and you are having trouble inserting the pack into a small envelope, be sure to set the "Envelope Width" and "Widest Enclosure Width" to the exact dimensions of the insertion pack. <ol style="list-style-type: none"> 1. From the Home screen, select "Menu", then "Jobs". 2. Select "Edit Current Job", "Edit Job Settings", then "Advanced". 3. Select "Aligner", then "On with Custom Settings". The Customer Aligner Settings screen displays. 4. Select "Envelope Width". Use the UP/DOWN arrow keys to increase or decrease the measurement, as necessary. Select "Accept" when done. 5. Select "Widest Enclosure Width". Use the UP/DOWN arrow keys to increase or decrease the measurement, as necessary. Select "Accept" when done. 6. Select "Accept" on the Custom Aligner Settings screen once the necessary adjustments have been made.
	Poor quality envelopes.	Check side seam(s) inside of envelope for excessive stickiness. Glue residue inside of the envelope may prevent it from opening fully and easily.

Troubleshooting (continued)

Table 5-7 Moistener/Mail Piece Exit Problems		
Problem	Cause	Action
Stoppage in envelope exit area.	Glue contamination or debris in transport.	Inspect and clean transport.
Box seal: material obstructs envelope fold, causing flat area at crease.	Materials are not inserted deep enough into envelope.	Adjust the Envelope Crease Line upstream so materials are inserted deeper into the envelope: <ol style="list-style-type: none"> 1. At the Home screen select: "Menu", then "Tools", then "Configure System", and finally "Set Envelope Crease". 2. Select the appropriate envelope position. 3. Press "Finished" three times to return to the Home screen. <p>IMPORTANT: This setting is a system setting; it will be effective for all the applications on the machine.</p>
Envelope exit through letter path is unreliable; envelope is damaged.	Collations may be too stiff to exit through the letter exit path.	If the envelope is longer than 152 mm, process it through the flat exit path: <ol style="list-style-type: none"> 1. At the Home screen select: "Menu", then "Job". 2. Select "Edit Current Job", then "Choose the Item to modify" and "Edit Highlighted Item". 3. Select "Additional Setting", then "Advanced", and "Stiff Media". 4. Select "Yes". <p>NOTES:</p> <ul style="list-style-type: none"> • If the Stiff media option is not available (grayed out), make sure that the Stiff Media option is enabled in the system setting. • If the envelope is not a flat envelope, the system will assign the envelope to a Tower feeder even if a HCEF is installed on the machine.

Table 5-11 Universal Feeder Problems		
Problem	Cause	Action
"Custom Feeder not Found" message displays.	The Universal Feeder and/or Input Transport may not be powered on.	Turn the Universal Feeder and/or Input Transport on. <p>NOTE: You may need to power the system off and then on again. When powering the system off and on, be sure to power off all modules, from left to right, then power them all back on from left to right.</p>

SI5200/SI5400/SI5400e Operator Guide Addendum

Reference

The information in this section is intended for use as a replacement or supplement to information contained in "Chapter 6, Reference" in the *SI5200/SI5400 Document Inserting System Operator Guide*.

System Specifications

Dimensions		
All dimensions are approximate.		
	Length overall, height	Weight, unboxed
Universal Feeder	39.4" (1000 mm), 18.5" (47 mm)	141 lb. (64 kg)
Universal Loader	35.4" (900 mm), 20" (51 mm)	132 lb. (60 kg)
Input Transport	20" (51 mm), 10.5" (27 mm)	42 lb. (19 kg)

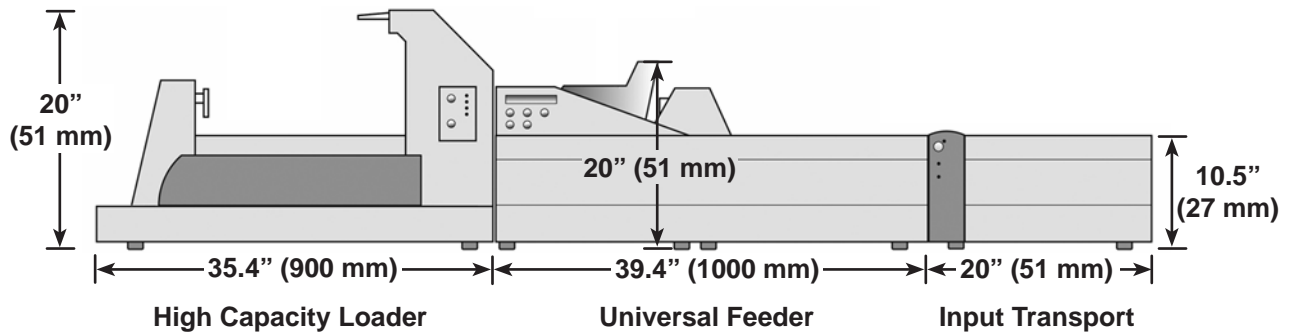

Universal Feeder

Refer to the *Universal Feeder/High Capacity Loader Operator Guide* for system specifications and requirements.

Feeder Tower Sheet Specifications

The following table replaces the *Feeder Tower - Sheet Specifications* table on page 6-11 of the *SI5200/SI5400 Document Inserting System Operator Guide*:

Feeder Tower - Sheet Specifications		
Parameter	Minimum Value	Maximum Value
Width	5 inches (127 mm)	9.84 inches (250 mm)
Length	6.7 in (170 mm)	14 inches (356 mm)
Thickness	0.003 inches (0.076 mm)	0.012 inches (0.305 mm)
Paper Weight	16 lb. (60 gsm)	44 lb. (175 gsm)

SI5200/SI5400/SI5400e Operator Guide Addendum

SI5200/SI5400 Input Transport

Material	Letter-size or A4 sheets or booklets
Sheet Dimensions	Width: 6.89" (175 mm) to 9.84" (250 mm) Length: 5.47" (139 mm) to 14.09" (358 mm) Basis Weight: 16 lb. (60 gsm) to 47 lb. (175 gsm)
Booklet Dimensions	Width: 5.31" (135 mm) to 9.84" (250 mm) Length: 3.66" (93 mm) to 11.81" (300 mm) Basis Weight: 24 lb. (90 gsm) to 47 lb. (175 gsm)
Throughput	<ul style="list-style-type: none"> A4 sheets: up to 5400 collations per hour. Letter-size sheets: up to 5500 collations per hour.
Notes	The processing capability of the Input Transport is limited by the requirements of the downstream upstream device (either the HCSF or Base). Refer to the "Chapter 6, Reference" in the <i>SI5200/SI5400 Document Inserting System Operator Guide</i> for these requirements.

If you are using the Input Transport divert trays, refer to the tables below to ensure the material meets the size specifications for each of the divert trays.

Lower Divert Tray		
Parameter	Minimum	Maximum
Width	5.31" (135 mm)	8.58" (218 mm)
Length	5.47" (180 mm)	14.09" (358 mm)

Upper Divert Tray		
Parameter	Minimum	Maximum
Width	8.19" (208 mm)	8.58" (218 mm)
Length	5.47" (180 mm)	14.09" (358 mm)

SI5200/SI5400/SI5400e Operator Guide Addendum

Add Ons and Options

The information in this section is intended for use as a supplement to “Chapter 7, Add Ons and Options” in the *SI5200/SI5400 Document Inserting System Operator Guide*.

Universal Feeder

The Universal Feeder takes laser printed or pre-print cut sheets and efficiently collates them into customer sets. It can also feed single booklets up to 4 mm (0.16”) thick. OMR/BCR/OCR/2D Matrix scanning ensures complete integrity and confidentiality of the sets.

Standard Features:

- Bottom feeding of material
- Variable speed control
- Overcount control
- Automatic double document detection
- Job storage - up to 99 jobs available
- Multi-function operator controls
- Easy to use self prompting display
- Out of material and jam detection
- Resettable sheet counter
- Batch count control
- Operator selectable ‘User Definable’ (if OMR scanning is fitted)

Refer to the *Universal Feeder/High Capacity Loader Operator Guide* for more information.

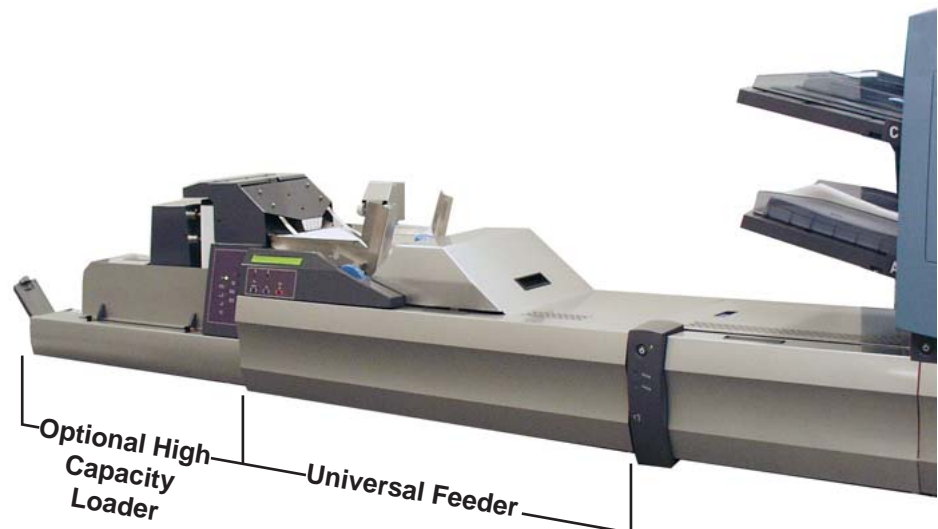

High Capacity Loader (Optional)

The optional High Capacity Loader takes laser printed or pre-printed cut sheets and conveys them to the feeder deck of the Universal Feeder.

The High Capacity loader comes in two versions; one is designed to handle US 'Letter'-sized sheets, whereas the other handles DIN A4 sized sheets.

After loading material into the High Capacity Loader, operation is controlled by the Universal Feeder. The High Capacity Loader will only convey material when instructed to do so by the Universal Feeder.

In the event of a material stoppage on the Universal Feeder, the High Capacity Loader will stop.

Standard Features:

- Automatic start/stop – Controlled by downstream Universal Feeder
- Automatic paper flow control
- Automatic material detection
- Fully interlocked covers
- Operator adjustment to accommodate 'curled material'

Refer to the *Universal Feeder/High Capacity Loader Operator Guide* for more information.

SI5200/SI5400 Input Transport

The SI5200/SI5400 Input Transport is located between the Universal Feeder and either:

- the base unit or the
- a High Capacity Sheet Feeder (HCSF).

The Input Transport receives sheet(s) (in the form of complete collations), inserts (or accumulations of inserts) and booklets from the Universal Feeder. It has the capability of buffering the material ahead of the base unit or HCSF until the downstream unit is ready to receive the material.

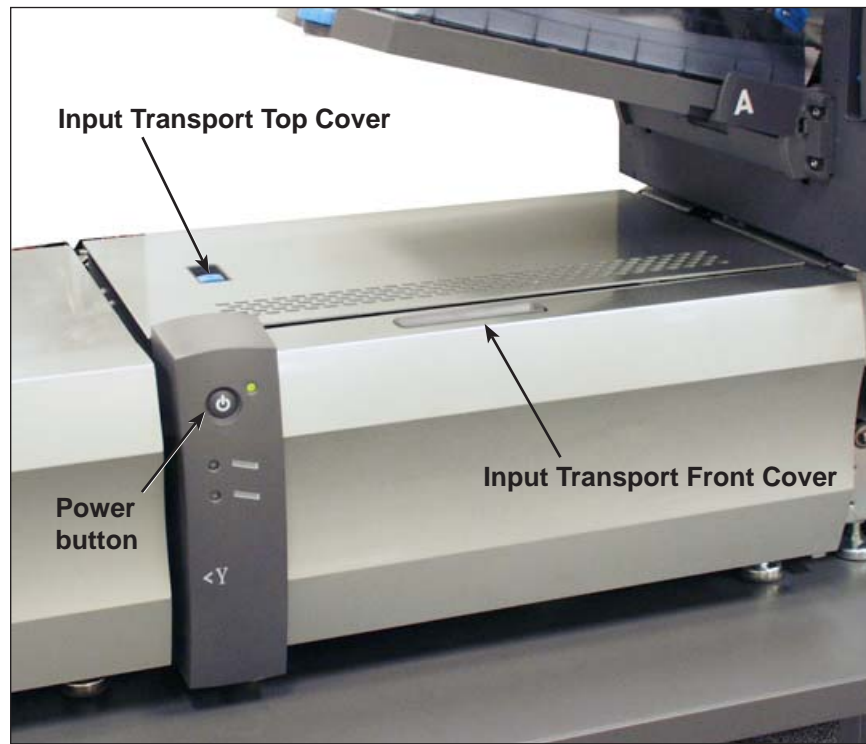

Input Transport Attached to Base Unit

SI5200/SI5400/SI5400e Operator Guide Addendum

SI5200/SI5400 Input Transport (continued)

The Input Transport has two sheet divert trays: an upper divert tray and a lower divert tray. The lower divert tray provides capacity and function identical to the divert tray shipped with the basic SI5200/SI5400 system. The upper divert tray provides a divert path accessible only to the upstream external device.

Upper Divert Tray

Lower Divert Tray



NOTES:

- Refer to *Reference, SI5200/SI5400 Input Transport* in this guide for divert tray material specifications.
 - The upper divert tray will accept input of up to 25 sheets with a basis weight of 32 lb. (120 gsm) per sheet.
 - Stiff media is not allowed in the upper divert tray since it will not be able to negotiate the bend down from the paper path into the divert path.
-

SI5200/SI5400/SI5400e Operator Guide Addendum

SI5200/SI5400 Input Transport (continued)

The front cover of the Input Transport has two LED lights: the upper light is for upper (upstream) divert tray; the lower light is for lower (SI5200/SI5400 base unit) divert tray. The LED lights indicate the following:

- *No light* means the divert tray is empty.
- *Green light* means tray has material in it.
- *Red light* means that tray is full.

LED for Upper Divert Tray



LED for Lower Divert Tray

SI5200/SI5400/SI5400e Operator Guide Addendum

SI5200/SI5400 Input Transport (continued)

There are two blue jam clearance knobs on the Input Transport.

- Knob 30 clears stoppages that occur while material enters the Input Transport.
- Knob 31 clears stoppages that occur while material exits the Input Transport.

NOTE: This knob also turns belts in the Feeder Tower. Be sure to open the Feeder Tower cover when clearing a stoppage using this knob.

To access the jam clearance knobs, open the Input Transport front cover.

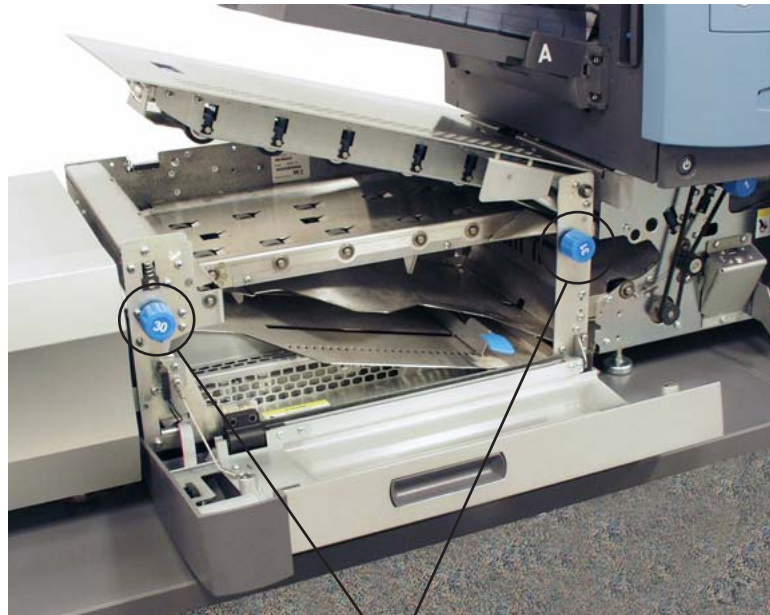

Jam Clearance Knobs

SI5200/SI5400 Input Transport (continued)

Adjusting the Stop on the Lower Divert Tray

Adjust the stop on the lower divert tray to the size of the material being fed into the tray.

NOTE: The system must be stopped in order to perform this procedure. Opening the covers while the system is running will cause an error.

1. Open the Input Transport covers.

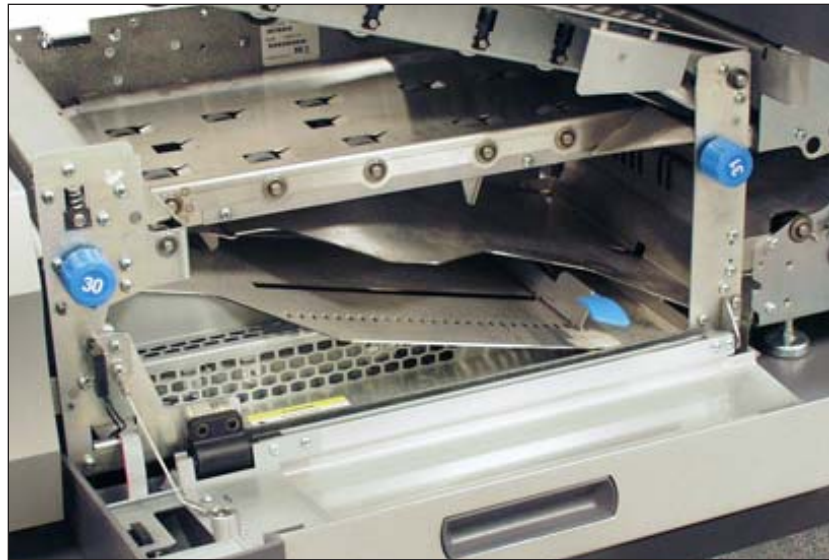

2. Lift the blue lever and slide the stop to the position that corresponds with the material size. Lower the stop into the appropriate slot to lock it in place. The letter (11") and A4 slots are marked for your convenience.



3. Close the Input Transport covers.

Scanning

The information in this section is intended to replace information contained in “Chapter 8, Scanning” in the *SI5200/SI5400 Document Inserting System Operator Guide*.

Scanning Features

Dynamic Envelope Selection

Dynamic envelope selection allows you to create scanning jobs on SI5400 systems (with or without a High Capacity Sheet Feeder) that will insert mail piece contents into either letter-sized or flat envelopes.

Letter-sized envelopes are loaded at the High Capacity Envelope Feeder. Flat envelopes are loaded at the Feeder Tower, and can be linked so that they feed from Feeder A and Feeder C.

NOTE: You cannot use a windowed flat envelope with Top Address, Z folded jobs. Dynamic envelope selection cannot be used when the stiff media insert is selected.

This feature is implemented in one of two ways:

- Using the Envelope Select (ES) scan mark. The Envelope Select scan mark is available on systems that have BCR scanning or the Selective Operations level of OMR scanning enabled. Refer to *BCR and OMR Mark Levels* in “Chapter 8, Scanning” of the *SI5200/SI5400 Document Inserting System Operator Guide* for more information about the various levels of scanning.
- Setting the “Item Overcount Action” to “Use Alternate Envelope”. Refer to *Creating a Job* in Chapter 3 or *Assigning a Scan Configuration to an Existing Job* in Chapter 8 of the *SI5200/SI5400 Document Inserting System Operator Guide* for more information.

Jobs using dynamic envelope selection must be set up with two outer envelopes. The first set in the job must contain the information necessary to make the envelope selection (either the Envelope Select scan mark or “Item Overcount Action” setting). Secondary sets of scanned material, generic (non-scanned) material, or sets containing select fed sheets can be included in a dynamic envelope selection job.

Additionally, a single Reply Envelope (BRE) can be included in the job. If you wish to add an insert type other than a BRE to the flat envelope, the insert must be called a BRE in the Mail Piece Icon Tree.

NOTE: Thick inserts (such as booklets) may have trouble accumulating in the Pre-fold Accumulator and are not recommended for use.

The BRE/insert will accumulate with the flat set in the Pre-fold Accumulator prior to insertion into the envelope.



10 Clipper Road
Conshohocken, PA 19428-2721
www.secapusa.com

For Service & Supplies contact your authorized SECAP dealer:

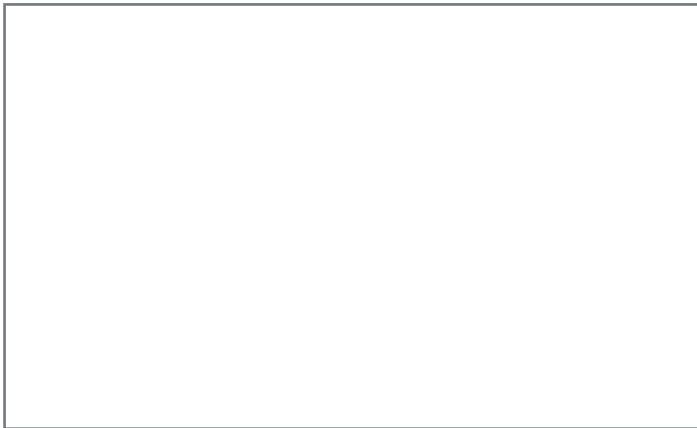

SV62169 Rev. A 4/08

